

CAD FILE:

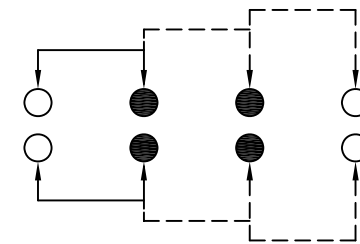

SCHEMATIC (NON-SHORTING)

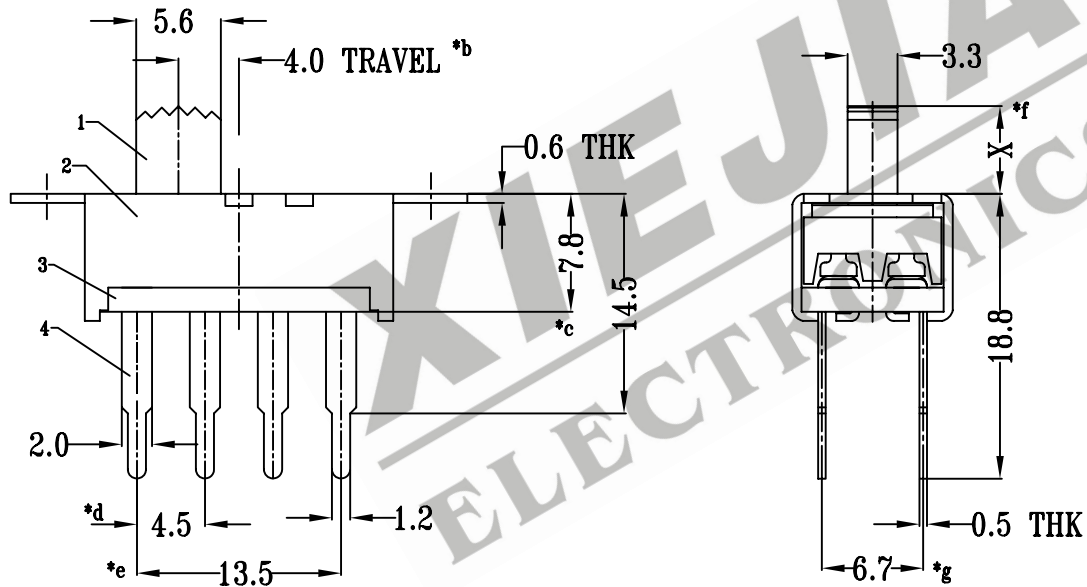
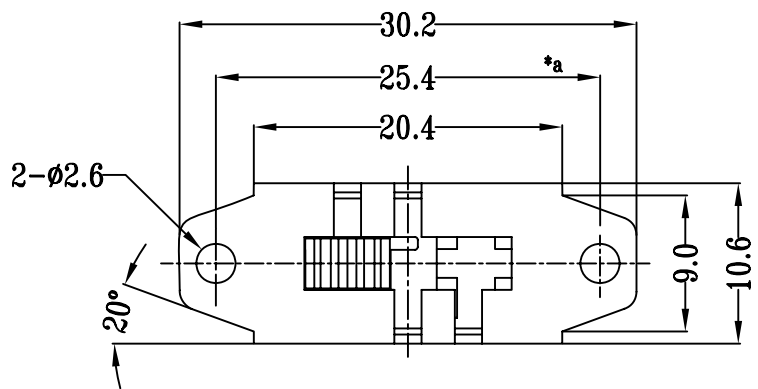
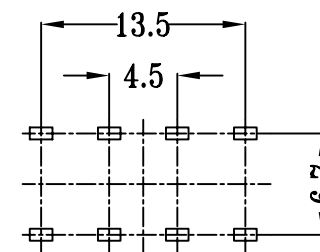

P.C.B LAYOUT

注:带"*"表示关键尺寸(7个)

NO.	PARTS	MATERIALS	Q'TY	FINISH	TOLERANCE UNLESS SPECIFIED	SHENZHEN XIEJIA ELECTRONICS CO.,LTD.			
8									
7									
6	SPRING PLATE	PBS STRIP	3	NATURAL	WITHIN: 1.5±0.1mm OVER : 1.5±0.2mm	ISSUE	DATE	DESCRIPTIONS OF REVISION	APPD.
5	CONTACT CLIP	COPPER STRIP	2	Ag PLATED					
4	TERMINAL	COPPER STRIP	8	Ag PLATED OVER Ni PLATED	TITLE : VERTICAL SLIDE SWITCH	UNIT : mm	DRWG NO.: XJ-DR-SS23H49-00		
3	BASE	PHENOLIC RESIN	1	BLACK	MODEL: SS-23H49	SCALE: 2 : 1	DWN.	ZHOUYU	2004-8-25
2	FRAME	STEEL STRIP	1	Zn PLATED			CHK'D	FANGYING	2004-8-25
1	KNOB	PC	1	BLACK	ALL MATERIALS MUST BE COMPLIANT TO ROHS		APPD.	KANGXINAN	2004-8-25